

# 150C Purlin Trestle

## C Purlin Trestle

---

### *User Manual*

Read in conjunction with  
Kwiktech Build Guide and  
Kwiktech Tips & Tricks

Designed by

**kwiktech.**

Engineered by

**sbec.** SCHMIDT  
BENTLEY  
ENGINEERING  
CONSULTING

Rating: 2 Tonne

Rev 1

This Manual is the sole property of  
Kwiktech Pty Ltd.  
All rights are reserved.

This Manual is designed to be only  
used with Kwiktech  
produced products.

No part of this Manual or the  
Kwiktech product design may be  
copied or reproduced without the  
consent of Kwiktech Pty Ltd.

Construction using Kwiktech  
products may require planning  
approval. Always contact your Local  
Council for the most up-to-date  
rules and regulations for your area.

All dimensions are in millimeters  
(mm)



# General Arrangement

## C Purlin Trestle

### User Manual

Read in conjunction with  
Kwiktech Build Guide and  
Kwiktech Tips & Tricks

Designed by

**kwiktech.**

Engineered by

**sbec.** SCHMIDT  
BENTLEY  
ENGINEERING  
CONSULTING

Rating: 2 Tonne

Rev 1

This Manual is the sole property of  
Kwiktech Pty Ltd.  
All rights are reserved.

This Manual is designed to be only  
used with Kwiktech  
produced products.

No part of this Manual or the  
Kwiktech product design may be  
copied or reproduced without the  
consent of Kwiktech Pty Ltd.

Construction using Kwiktech  
products may require planning  
approval. Always contact your Local  
Council for the most up-to-date  
rules and regulations for your area.

All dimensions are in millimeters  
(mm)

[www.kwiktech.com.au](http://www.kwiktech.com.au)

© Kwiktech Pty Ltd 2022

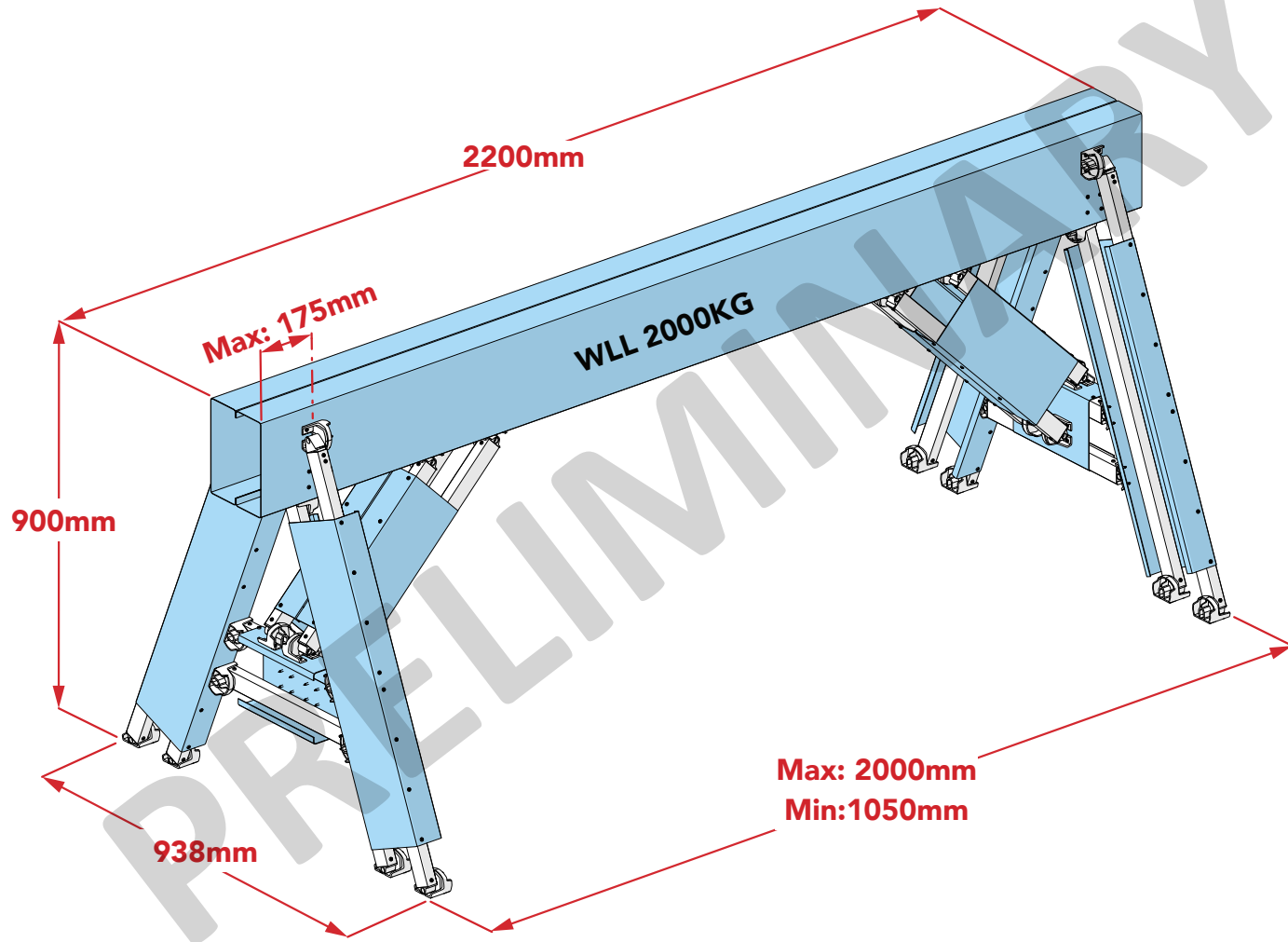

# Materials List

## C Purlin Trestle

### User Manual

Read in conjunction with Kwiktech Build Guide and Kwiktech Tips & Tricks

Designed by



Engineered by



Rating: 2 Tonne

Rev 1

This Manual is the sole property of Kwiktech Pty Ltd. All rights are reserved.

This Manual is designed to be only used with Kwiktech produced products.

No part of this Manual or the Kwiktech product design may be copied or reproduced without the consent of Kwiktech Pty Ltd.

Construction using Kwiktech products may require planning approval. Always contact your Local Council for the most up-to-date rules and regulations for your area.

All dimensions are in millimeters (mm)

## KWIKTECH KITS

ITEM	QUANTITY	RESELLER PRICE
Kwiktech DIY Square Kit (NOTE: Some items will not be used)	2	
Kwiktech DIY Creator Kit (NOTE: Some items will not be used)	1	

## NON KWIKTECH ITEMS

ITEM	ITEM ID #	ASSEMBLY ID #	LENGTH	COLOUR	QUANTITY	RESELLER PRICE
C200-10 Purlin	①		2200*	Galv	2	
C150-10 Purlin	②	A B	654	Galv	4	
C150-10 Purlin	③	C D	353	Galv	4	
C150-10 Purlin	④	E	241	Galv	2	
RHS 38x25x1.2mm	⑤	A B	870	Galv	4	
RHS 38x25x1.2mm	⑥	C D	724	Galv	4	
RHS 38x25x1.2mm	⑦	A B	576	Galv	4	
RHS 38x25x1.2mm	⑧	C D	424	Galv	4	
RHS 38x25x1.2mm	⑨	E	390	Galv	2	
RHS 38x25x1.2mm	⑩	E	297	Galv	2	
SHS 65x65x2.0mm	⑪		199	Galv	4	
10G x 16 Self Drilling Wafer Head Screw	-	-	16	Galv	170	
					Sub-Total	
					GST	
					Shipping	
					Total Cost	

\*Note: 1050mm to 2300mm

## REQUIRED KWIKTECH ITEMS (INCLUDED IN KIT)

ITEM	QUANTITY	ITEM	QUANTITY
Post Connector (KT-P-001)	0	10G x 16 Self Drilling Wafer Head Screw	250
Universal Connector (KT-P-002)	40	M6 x 40 Socket Head Cap Screw - Zinc	40
Rail Inserts (KT-P-003)	32	M6 x 20 Hex Head Bolt - Galv	0
60° Rail Inserts (KT-P-004)	8	M6 Nut - Galv	0
Star Picket Guide (KT-P-005)	0	Kwiktech 2mm Displacement Plate	0
Post Cap (KT-P-006)	0	Right Angle Bracket - Zinc	3
Tension Strapping 0.8 x 30 x 85mm	0	Assembly Wedge - Rubber	0
Tension Strapping 0.8x 30 x 95mm	0	10G x 16 Self Drilling Small Head Flat Top Screw	0
Tension Strapping 0.8 x 30 x 135mm	0	Tension Strapping 0.8 x 30 x 250mm	0

## HOLLOW METAL

ITEM	TOTAL LENGTH
Duragal C200-15 Purlin	4.6m
Duragal C150-10 Purlin	4.6m
Duragal 38x25x1.2mm	12m
Duragal 65x65x2.0mm	0.8m

FOR INFORMATION ONLY

# Member Locations

## C Purlin Trestle

### User Manual

Read in conjunction with  
Kwiktech Build Guide and  
Kwiktech Tips & Tricks

Designed by

**kwiktech.**

Engineered by

**sbec.** SCHMIDT  
BENTLEY  
ENGINEERING  
CONSULTING

Rating: 2 Tonne

Rev 1

This Manual is the sole property of  
Kwiktech Pty Ltd.  
All rights are reserved.

This Manual is designed to be only  
used with Kwiktech  
produced products.

No part of this Manual or the  
Kwiktech product design may be  
copied or reproduced without the  
consent of Kwiktech Pty Ltd.

Construction using Kwiktech  
products may require planning  
approval. Always contact your Local  
Council for the most up-to-date  
rules and regulations for your area.

All dimensions are in millimeters  
(mm)

[www.kwiktech.com.au](http://www.kwiktech.com.au)  
© Kwiktech Pty Ltd 2022

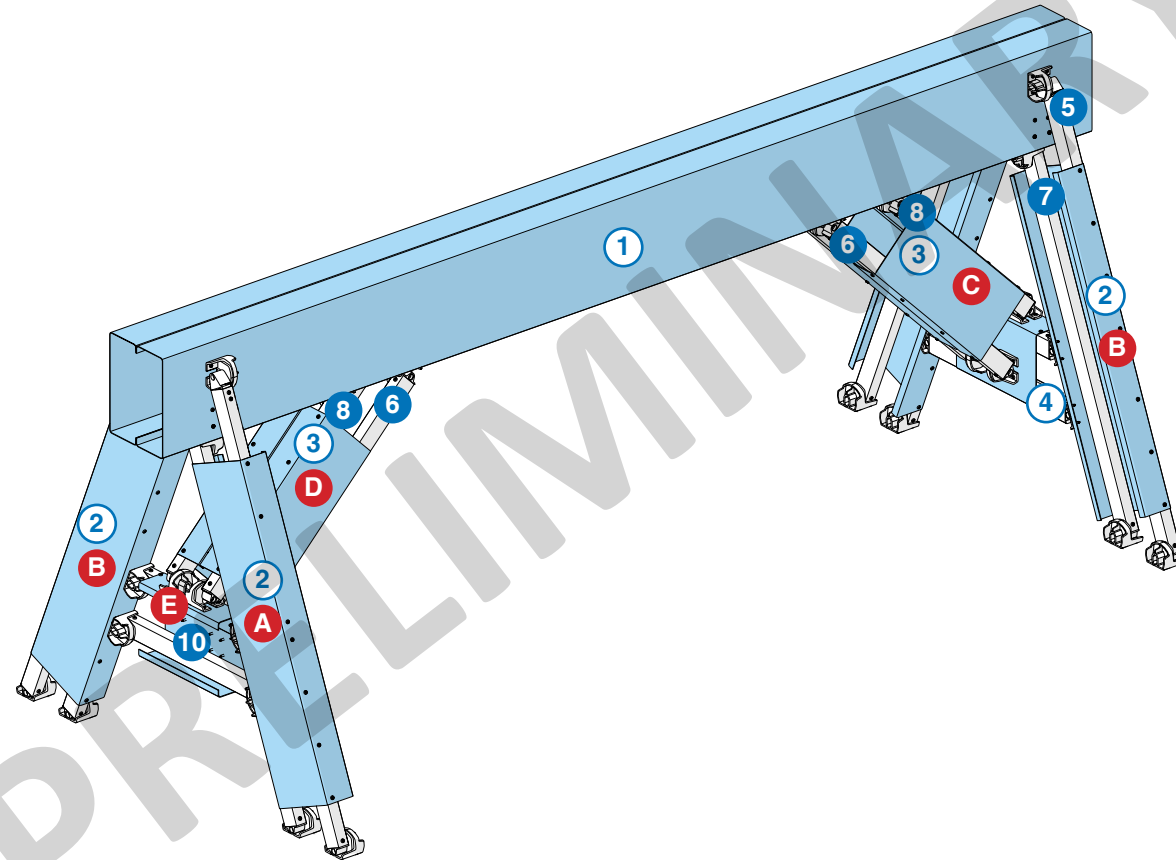

**NOTE:** Some member ID's hidden for clarity.

# Rail Assembly

C Purlin Trestle

User Manual

Read in conjunction with  
Kwiktech Build Guide and  
Kwiktech Tips & Tricks

Designed by

**kwiktech.**

Engineered by

**sbec.** SCHMIDT  
BENTLEY  
ENGINEERING  
CONSULTING

Rating: 2 Tonne

Rev 1

This Manual is the sole property of  
Kwiktech Pty Ltd.  
All rights are reserved.

This Manual is designed to be only  
used with Kwiktech  
produced products.

No part of this Manual or the  
Kwiktech product design may be  
copied or reproduced without the  
consent of Kwiktech Pty Ltd.

Construction using Kwiktech  
products may require planning  
approval. Always contact your Local  
Council for the most up-to-date  
rules and regulations for your area.

All dimensions are in millimeters  
(mm)

[www.kwiktech.com.au](http://www.kwiktech.com.au)  
© Kwiktech Pty Ltd 2022

## Rail Setup

Refer to build guide for  
assembly details.

All members have a  
Standard insert unless  
otherwise noted.

Mark item ID on each member.

### RAIL INSERT TYPES

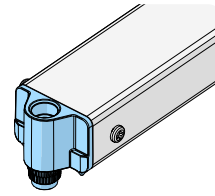

Standard

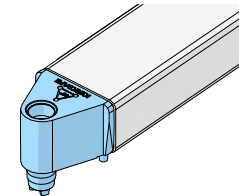

60°

Note: Keep the 60° connector  
loose until assembled. When  
assembled, fix in place with x2  
screws on the exterior side.

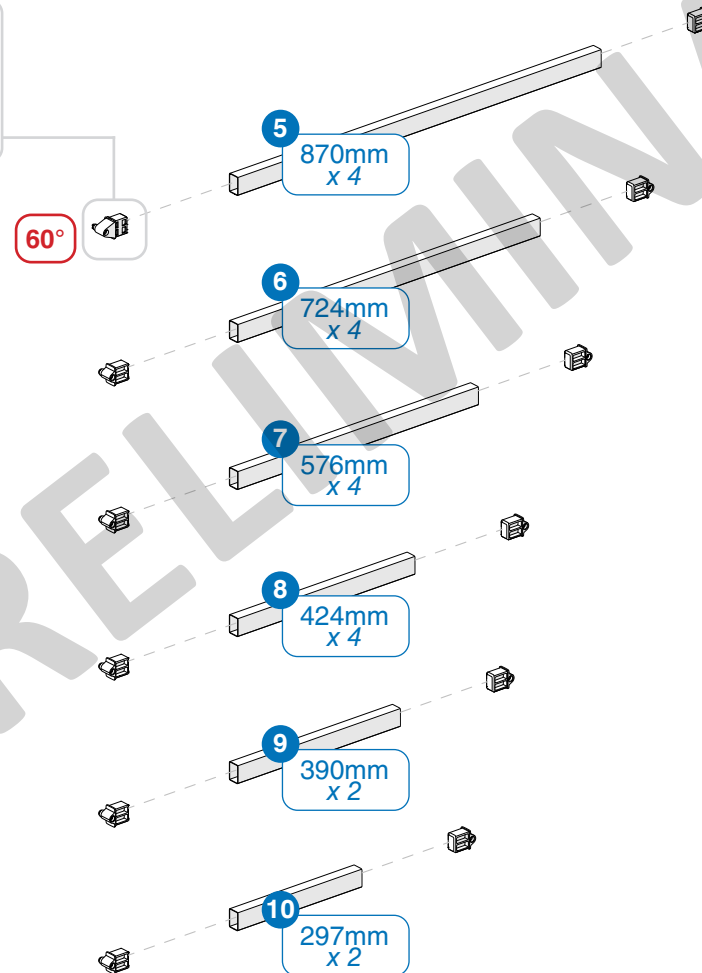

# Extra Strong Rail Assembly

C Purlin Trestle

User Manual

Read in conjunction with  
Kwiktech Build Guide and  
Kwiktech Tips & Tricks

Designed by

**kwiktech.**

Engineered by

**sbec.** SCHMIDT  
BENTLEY  
ENGINEERING  
CONSULTING

Rating: 2 Tonne

Rev 1

This Manual is the sole property of  
Kwiktech Pty Ltd.  
All rights are reserved.

This Manual is designed to be only  
used with Kwiktech  
produced products.

No part of this Manual or the  
Kwiktech product design may be  
copied or reproduced without the  
consent of Kwiktech Pty Ltd.

Construction using Kwiktech  
products may require planning  
approval. Always contact your Local  
Council for the most up-to-date  
rules and regulations for your area.

All dimensions are in millimeters  
(mm)

[www.kwiktech.com.au](http://www.kwiktech.com.au)  
© Kwiktech Pty Ltd 2022

## Rail Setup

Refer to build guide  
for assembly details.

Mark assembly ID  
on each member.

Use of C Clamp  
recommended for Rail  
to C Purlin Fixing

## MEMBER ORIENTATION

38x25 flush with the side  
& 1 mm off the internal face  
of the C Purlin.

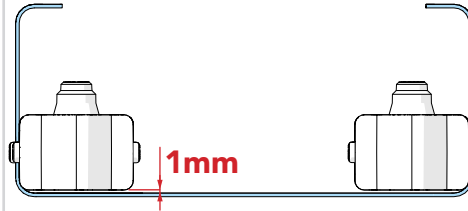

## ENDS FIXING DETAIL

Screw 10mm from end of  
the C Purlin.

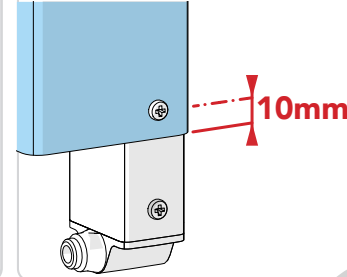

## FIXING DETAIL

Screws from C  
Purlin into 38x25.  
100mm spacing  
until screws meet  
in the middle.

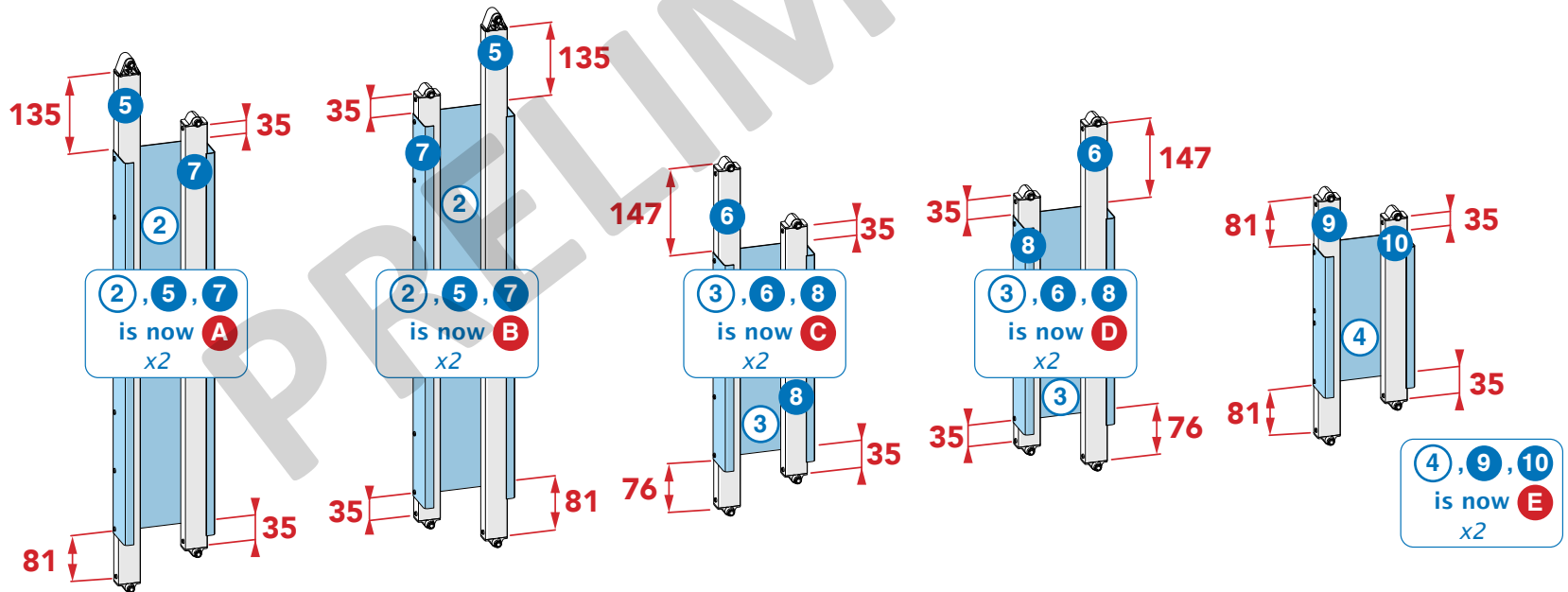
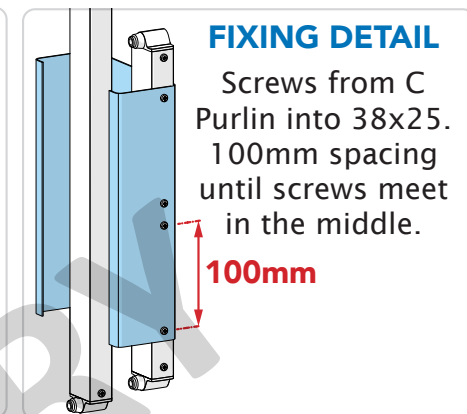

# Universal Connector Locations

## C Purlin Trestle

User Manual

Read in conjunction with Kwiktech Build Guide and Kwiktech Tips & Tricks

Designed by



Engineered by



Rating: 2 Tonne

Rev 1

This Manual is the sole property of Kwiktech Pty Ltd. All rights are reserved.

This Manual is designed to be only used with Kwiktech produced products.

No part of this Manual or the Kwiktech product design may be copied or reproduced without the consent of Kwiktech Pty Ltd.

Construction using Kwiktech products may require planning approval. Always contact your Local Council for the most up-to-date rules and regulations for your area.

All dimensions are in millimeters (mm)

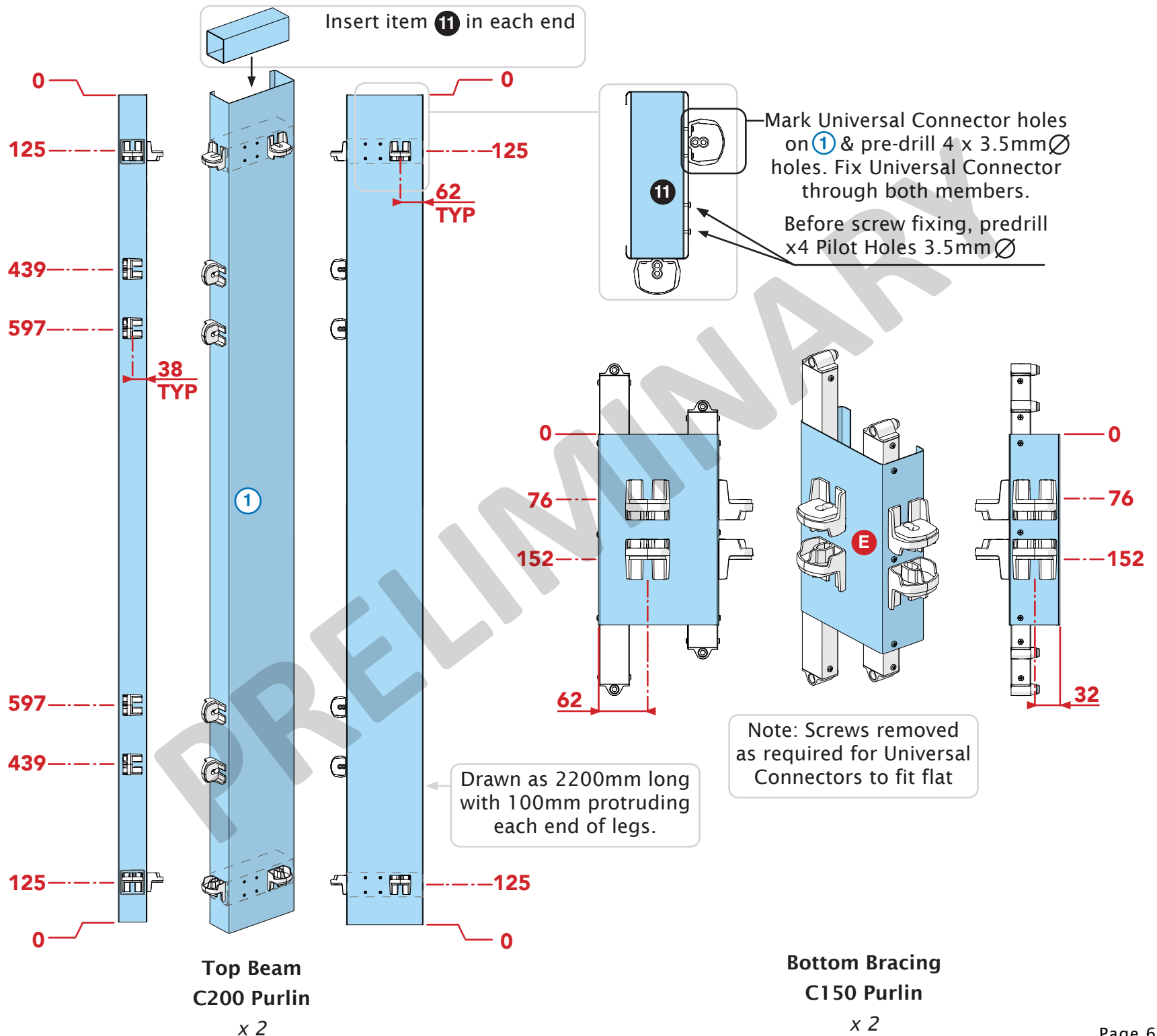

# Universal Connector Locations

## C Purlin Trestle

User Manual

Read in conjunction with  
Kwiktech Build Guide and  
Kwiktech Tips & Tricks

Designed by

**kwiktech.**

Engineered by

**sbec.** SCHMIDT  
BENTLEY  
ENGINEERING  
CONSULTING

Rating: 2 Tonne

Rev 1

This Manual is the sole property of  
Kwiktech Pty Ltd.  
All rights are reserved.

This Manual is designed to be only  
used with Kwiktech  
produced products.

No part of this Manual or the  
Kwiktech product design may be  
copied or reproduced without the  
consent of Kwiktech Pty Ltd.

Construction using Kwiktech  
products may require planning  
approval. Always contact your Local  
Council for the most up-to-date  
rules and regulations for your area.

All dimensions are in millimeters  
(mm)

www.kwiktech.com.au  
© Kwiktech Pty Ltd 2022

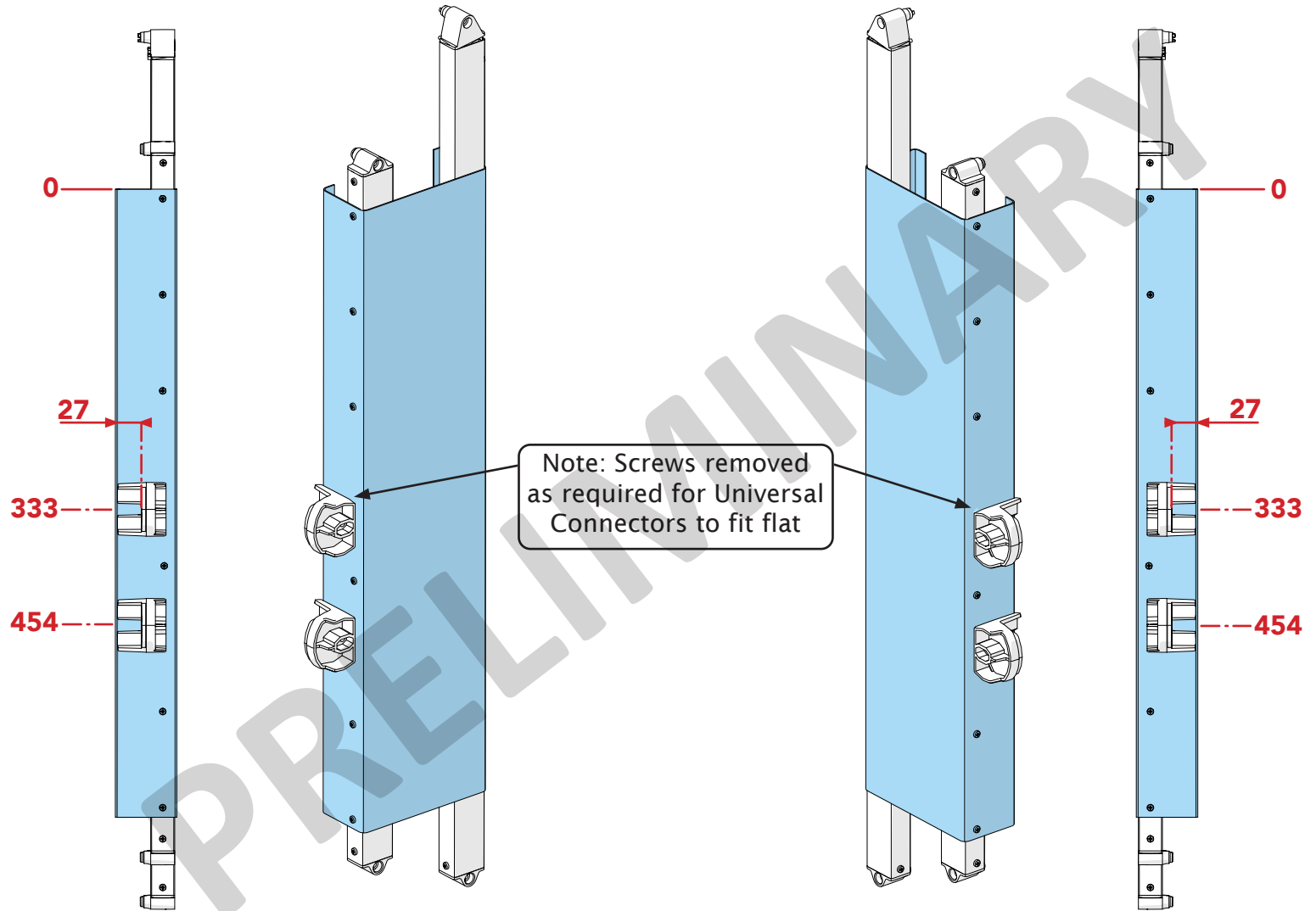

**Angled Legs A**  
**C150 Purlin**  
x 2

**Angled Legs B**  
**C150 Purlin**  
x 2



# Assembly Steps

## C Purlin Trestle

User Manual

Read in conjunction with  
Kwiktech Build Guide and  
Kwiktech Tips & Tricks

Designed by

**kwiktech.**

Engineered by

**sbec.** SCHMIDT  
BENTLEY  
ENGINEERING  
CONSULTING

Rating: 2 Tonne

Rev 1

This Manual is the sole property of  
Kwiktech Pty Ltd.  
All rights are reserved.

This Manual is designed to be only  
used with Kwiktech  
produced products.

No part of this Manual or the  
Kwiktech product design may be  
copied or reproduced without the  
consent of Kwiktech Pty Ltd.

Construction using Kwiktech  
products may require planning  
approval. Always contact your Local  
Council for the most up-to-date  
rules and regulations for your area.

All dimensions are in millimeters  
(mm)

[www.kwiktech.com.au](http://www.kwiktech.com.au)  
© Kwiktech Pty Ltd 2022

### Step 1

Assemble both leg ends.

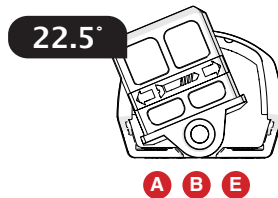
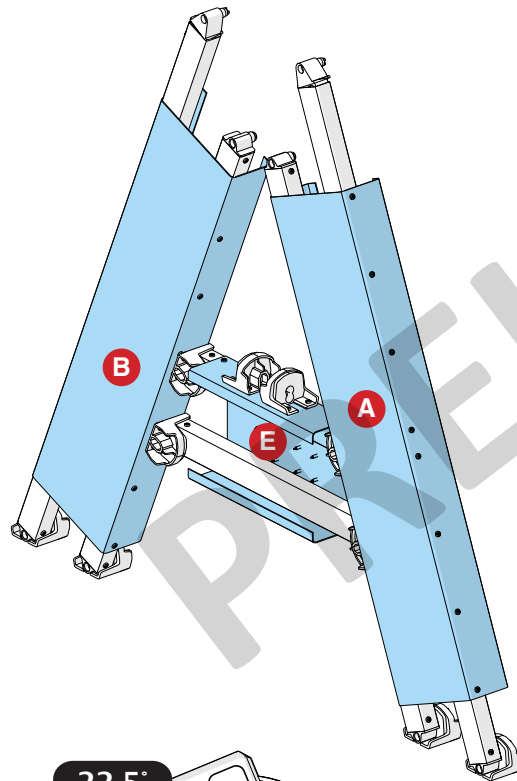

### Step 2

Secure leg ends to C Purlins. Fix 60°  
Connectors in place with 2 screws.

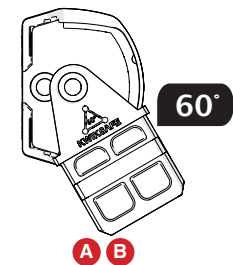
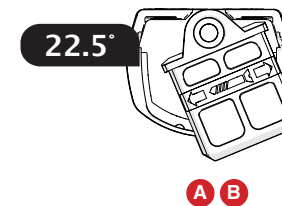
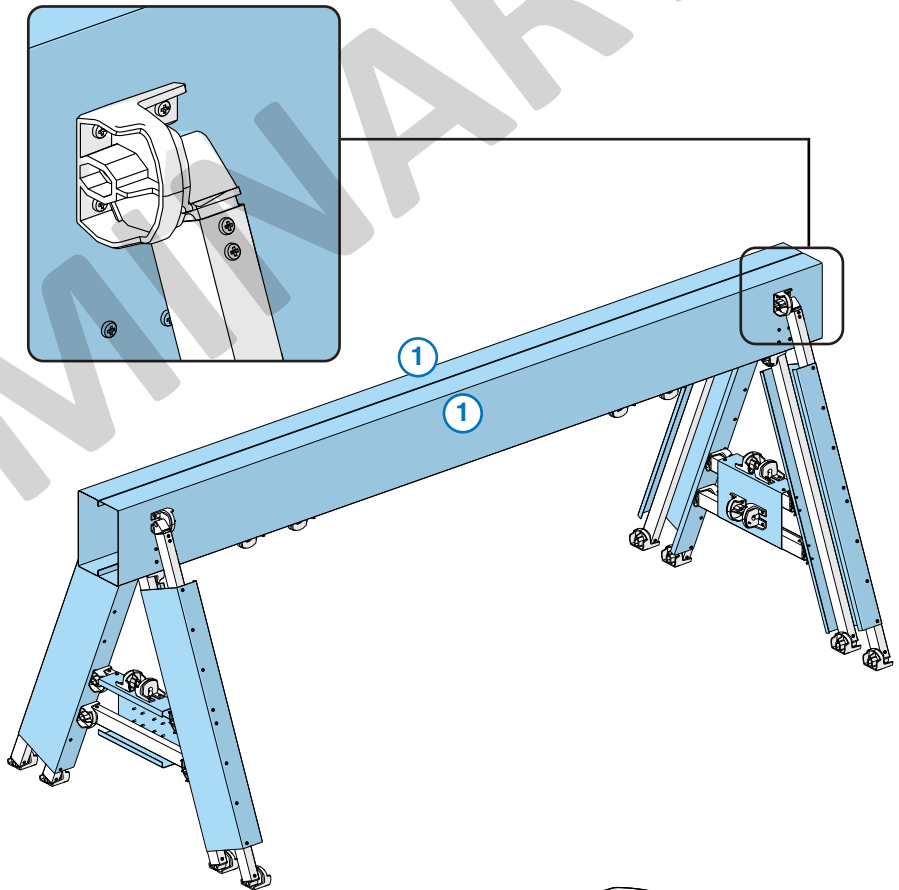

# Assembly Steps

## C Purlin Trestle

### User Manual

Read in conjunction with  
Kwiktech Build Guide and  
Kwiktech Tips & Tricks

Designed by

**kwiktech.**

Engineered by

**sbec.** SCHMIDT  
BENTLEY  
ENGINEERING  
CONSULTING

Rating: 2 Tonne

Rev 1

This Manual is the sole property of  
Kwiktech Pty Ltd.  
All rights are reserved.

This Manual is designed to be only  
used with Kwiktech  
produced products.

No part of this Manual or the  
Kwiktech product design may be  
copied or reproduced without the  
consent of Kwiktech Pty Ltd.

Construction using Kwiktech  
products may require planning  
approval. Always contact your Local  
Council for the most up-to-date  
rules and regulations for your area.

All dimensions are in millimeters  
(mm)

[www.kwiktech.com.au](http://www.kwiktech.com.au)  
© Kwiktech Pty Ltd 2022

### Step 3

Secure Trestle legs with underside diagonal bracing.

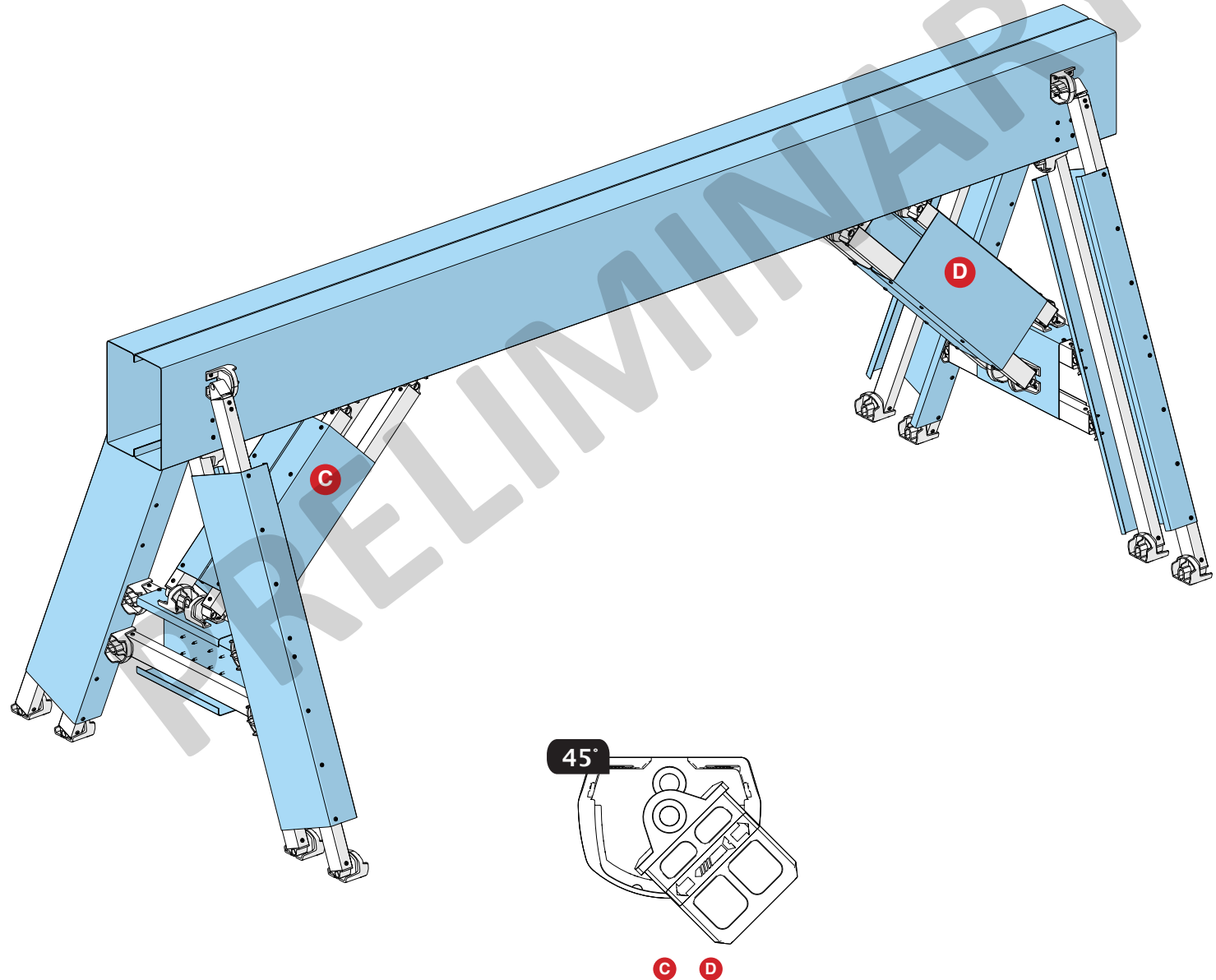

# Blueprint Dimensions

## C Purlin Trestle

### User Manual

Read in conjunction with  
Kwiktech Build Guide and  
Kwiktech Tips & Tricks

Designed by



Engineered by



Rating: 2 Tonne

Rev 1

This Manual is the sole property of  
Kwiktech Pty Ltd.  
All rights are reserved.

This Manual is designed to be only  
used with Kwiktech  
produced products.

No part of this Manual or the  
Kwiktech product design may be  
copied or reproduced without the  
consent of Kwiktech Pty Ltd.

Construction using Kwiktech  
products may require planning  
approval. Always contact your Local  
Council for the most up-to-date  
rules and regulations for your area.

All dimensions are in millimeters  
(mm)

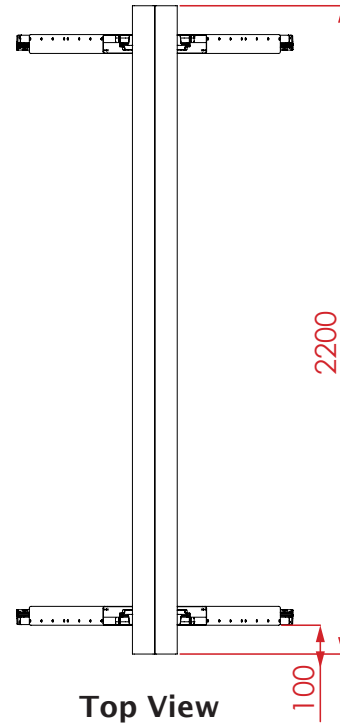

Top View

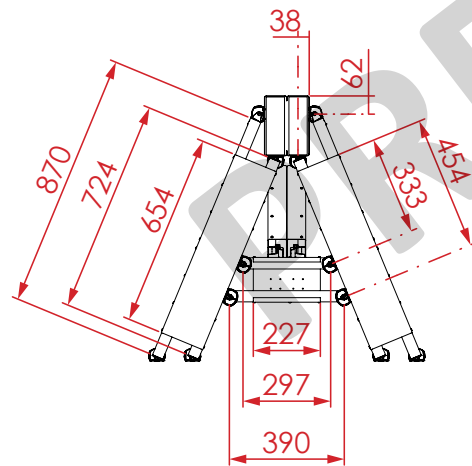

End View

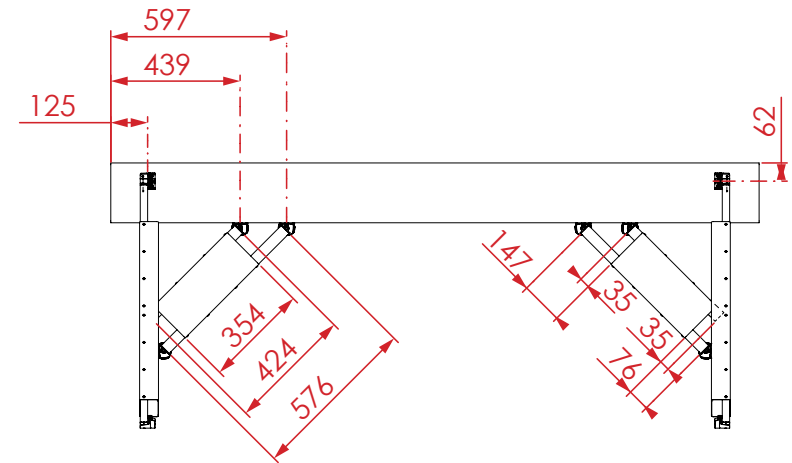

Side View